

John Deere 1900 / 1910 Overall Assembly

1) Hardware for this assembly comes with the respective upper and lower hardware kits.

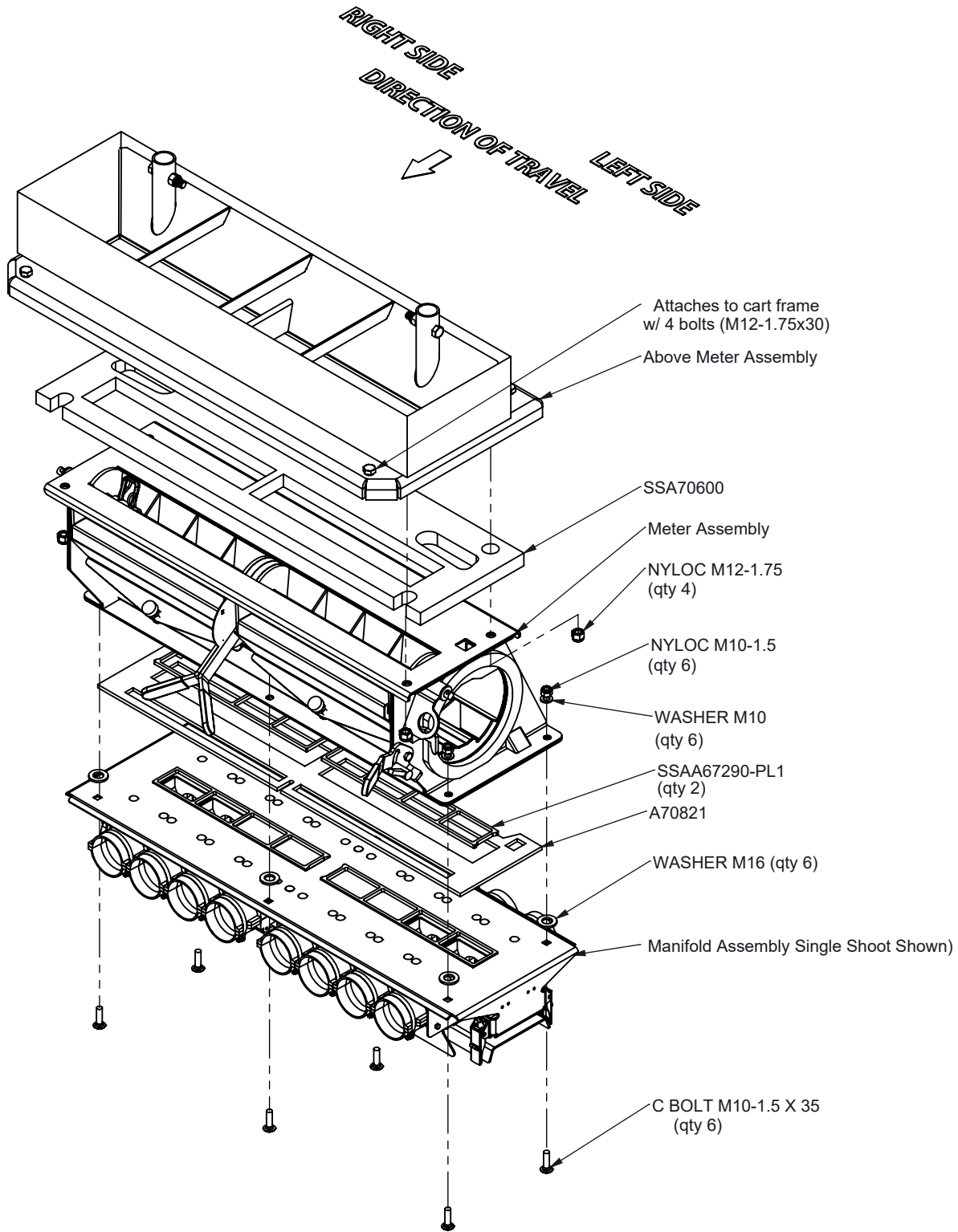

John Deere 1900 / 1910 Above the meter Assembly

- A) Hardware included in package "UHK1-SS"
- B) Trim stud flush to M12 nut after attaching funnel to base plate

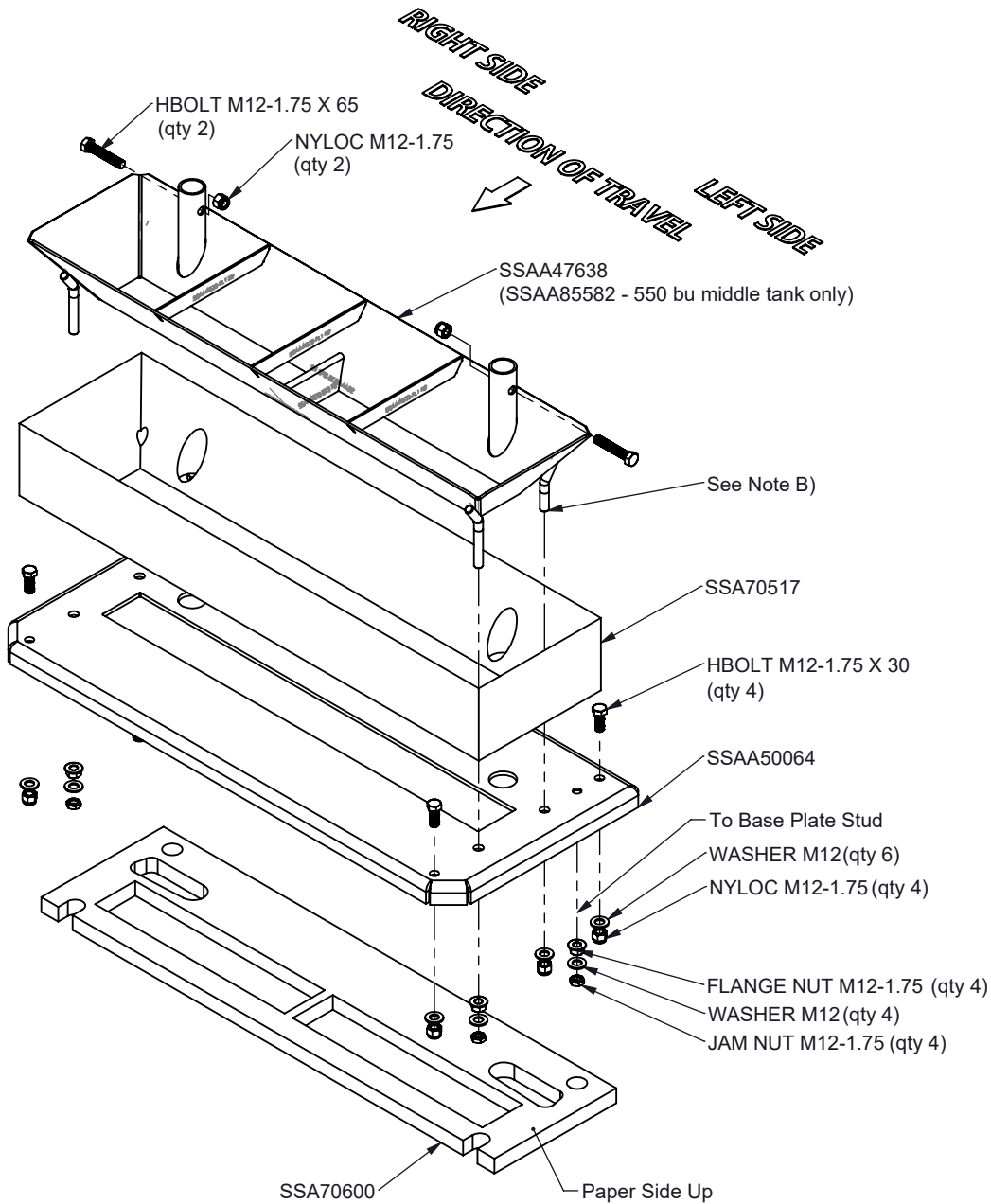

John Deere 1900 / 1910 Meter Housing Assembly

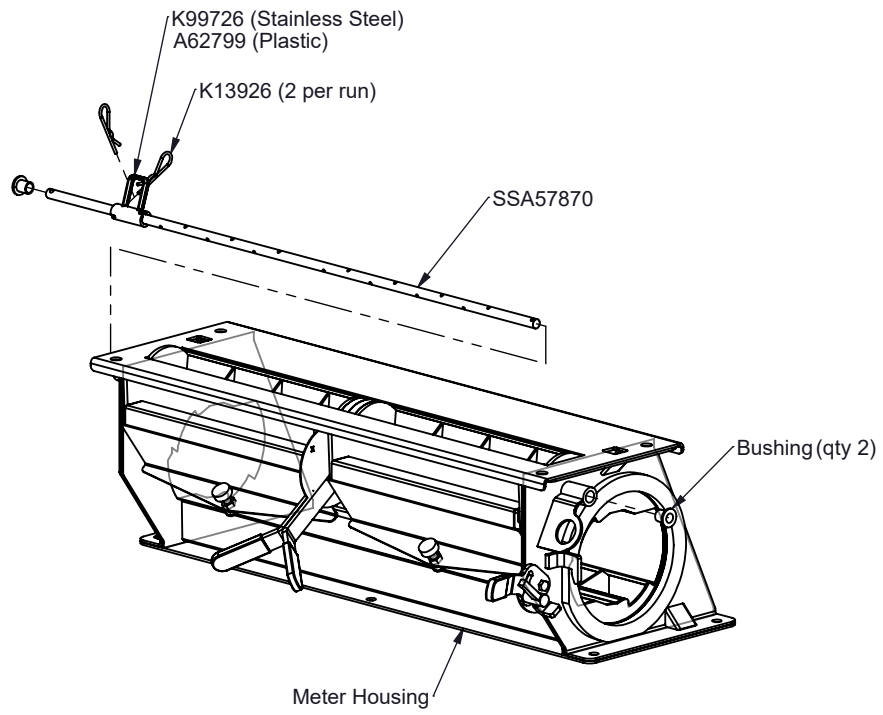

John Deere 1900 / 1910 Below the Meter Assembly (Single Shoot)

- A) Hardware included in package "LHK1-SS"
- B) Stack washers as shims to set proper cleanout seal
- C) Use fill plate based on runs installed on your cart
- D) Use these plates if installing aftermarket stainless meter

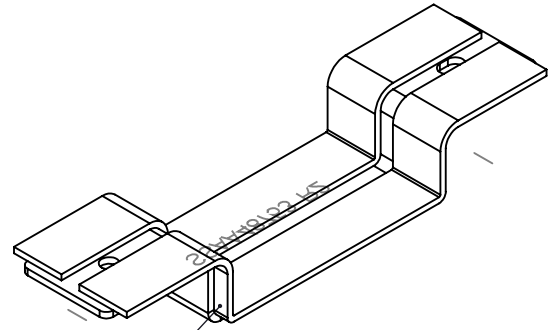

Apply seal strip with
1/4" protruding each side

